

Emergence of the Dirac Equation in the Solitonic Source of the Kerr Spinning Particle

Alexander Burinskii

Laboratory of Theor. Phys. NSI Russian Academy of Sciences, B. Tulkaya 52 Moscow 115191 Russia, *

The Kerr-Newman (KN) solution has many remarkable properties indicating its relationships with the structure of the Dirac electron. We consider a soliton source of the KN solution satisfying the requirement of maximal correspondence to flat quantum background, i.e. the full suppressing of gravity in the source region. The resulting regular source takes the form of a bag confining the Higgs field in a false-vacuum state. We show the origin of the Dirac equation from twistorial structure of the Kerr geometry, and discuss relationships of this model with the known MIT and SLAC bag models, and obtain specific features of the bag models related with the required long-range external gravitational field and with two-sheeted structure of the KN solution.

PACS numbers: 11.27.+d, 04.20.Jb, 04.60.-m, 04.70.Bw

1. It has been discussed for long time that black holes (BH) have to be related with elementary particles [1]. However, spin and charge of particles prevent formation of the BH horizons. A BH loses the horizons if the charge e or spin parameter $a = J/m$ exceeds the mass m (in the dimensionless units $G = c = \hbar = 1$). For example, the electron charge exceeds the mass for 21 order, while its spin/mass ratio is about 10^{22} , and the BH threshold $a \leq m$ is exceeded for 44 orders. Similar relations are valid for the other elementary particles, and besides the Higgs boson, which has neither spin nor charge, none of the elementary particles may be associated with a black hole. Meanwhile, it does not mean that it concerns the over-rotating BH geometry without horizons.

As it was shown by Carter [2], the Kerr-Newman rotating BH solution has gyromagnetic ratio $g = 2$ as that of the Dirac electron, and the four measurable parameters of the electron: spin, mass, charge and magnetic moment shows unambiguously that gravitational and electromagnetic field of the electron should correspond to over-rotating Kerr-Newman (KN) solution. The corresponding space has topological defect – the naked Kerr singular ring, which forms a branch line of space into two sheets: the sheet of advanced and sheet of the retarded fields. The Kerr-Schild form of metric

$$g_{\mu\nu} = \eta_{\mu\nu} + 2Hk_{\mu}k_{\nu}, \quad (1)$$

in which $\eta_{\mu\nu}$ is metric of auxiliary Minkowski space M^4 , and k_{μ} is a null vector field, $k_{\mu}k^{\mu} = 0$, forming the Principal Null Congruence (PNC) \mathcal{K} . [35] These retarded and advanced sheets are related by analytic transfer of the PNC via disk $r = 0$ spanned by the Kerr singular ring $r = 0, \cos\theta = 0$ (see fig.1). So far as r is the Kerr ellipsoidal radial coordinate, the surface $r = 0$ represents a disklike "door" from negative sheet $r < 0$ to positive one $r > 0$. The null vector fields $k^{\mu\pm}(x)$ differ on these sheets, and form the different null congruences \mathcal{K}^{\pm} , cre-

ating different metrics

$$g_{\mu\nu}^{\pm} = \eta_{\mu\nu} + 2Hk_{\mu}^{\pm}k_{\nu}^{\pm} \quad (2)$$

on the same Minkowski background M^4 . This mysterious twosheetedness caused search for different models of the source of Kerr geometry without negative sheet. Singular

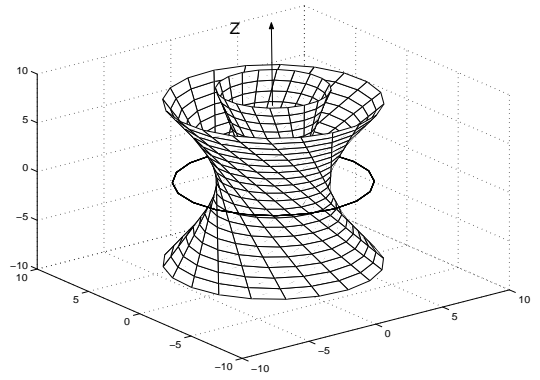

FIG. 1: Kerr's principal congruence of the null lines (twistors) is focused on the Kerr singular ring, forming a branch line of the Kerr space into two sheets.

metric conflicts with basic principles of quantum theory which is settled on the flat space-time and negligible gravitation. Resolution of this conflict requires "regularization" of space-time, which has to be done *before quantization, i.e. on the classical level*. Singular region has to be excised and replaced by a regular core with a flat internal metric $\eta_{\mu\nu}$, matching with external KN solution. Long-term search for the models of regular source (H. Keres (1966), W. Israel (1970), V. Hamity (1976), C. López (1984) at al.) [3–6] resulted in appearance of the gravitating soliton model [7, 8] which represents a domain-wall bubble, or a bag confining the Higgs field in a superconducting false-vacuum state. Such a matter regulates the KN electromagnetic (EM) field pushing it from interior of the bag to domain wall boundary and results in the consistency with flat internal metric required by Quantum theory. The Higgs mechanism of broken symmetry approaches this model with the known models

*email: bur@ibrae.ac.ru

of MIT- and SLAC- bags, and with the Coleman Q-ball models [9, 10], considered as electroweak soliton models in [11–13]. The used in MIT- and SLAC- bag models quartic potential for the self-interacting Higgs field Φ ,

$$V(|\Phi|) = g(\bar{\sigma}\sigma - \eta^2)^2, \quad (3)$$

describes a spontaneously broken theory, in which vacuum expectation value (vev) of the Higgs field $\sigma = \langle |\Phi| \rangle$ vanishes inside the bag, $r < R$, and takes nonvanishing value $\sigma = \eta$, *outside the bag*, $r > R$. The Dirac equation of the SLAC -bag theory in the presence of the classical σ -field takes the form

$$(i\gamma^\mu \partial_\mu - g\sigma)\psi = 0, \quad (4)$$

where g is a dimensionless coupling parameter. This expression shows that the Dirac field ψ acquires effective mass $m = g\sigma$ from the vev of Higgs field σ . Inside the bag the Dirac field is massless, while outside the bag the wave function ψ may acquire large mass $m = g\eta$. The quarks are confined, preferring a more favorable energetic position inside the bag, which is the principal idea of the confinement mechanism.

2. Such a structure of the broken symmetry is not appropriate for the gravitating KN soliton model, since the vev of Higgs field σ breaks also the gauge symmetry the gravitational and electromagnetic (EM) external KN fields, turning them into short-range ones. An opposite (dual) geometry is realized in the Coleman's Q-ball models [9, 10], in which the Higgs field is confined inside the ball, $r < R$, and the external vacuum state is unbroken. However, formation of the corresponding potential turns out to be a very non-trivial problem, and we have showed in [7] that this type of broken symmetry may be obtained by using supersymmetric scheme of phase transition with three chiral fields $\Phi^{(i)}$, $i = 1, 2, 3$, [23]. One of this fields, say $\Phi^{(1)}$, has the required radial dependence, and we chose it as the Higgs field \mathcal{H} , setting the additional notations in accord with $(\mathcal{H}, Z, \Sigma) \equiv (\Phi^0, \Phi^1, \Phi^2)$. The required potential $V(r) = \sum_i |\partial_i W|^2$ is obtained from the superpotential (suggested by J.Morris, see ref. in [24]) $W(\Phi^i, \bar{\Phi}^i) = \lambda Z(\Sigma\bar{\Sigma} - \eta^2) + (Z + \mu)\mathcal{H}\bar{\mathcal{H}}$, where μ , η , λ are real constants. The condition $\partial_i W = 0$ determines two vacuum states separated by a spike of the potential V at $r = R$:

(I) external vacuum, $r > R$, $V(r) = 0$, with vanishing Higgs field $\mathcal{H} = 0$, and

(II) internal state of false vacuum, $r < R$, $V(r) = 0$, with broken symmetry, $|\mathcal{H}| = \eta\lambda^{-1/2} = \text{const.}$

Domain wall boundary of the phase transition between the states (I) and (II) is determined by matching the external KN metric $g_{\mu\nu} = \eta_{\mu\nu} + 2Hk_\mu k_\nu$, where

$$H = \frac{mr - e^2/2}{r^2 + a^2 \cos^2 \theta} \quad (5)$$

with flat internal metric $g_{\mu\nu} = \eta_{\mu\nu}$. It fixes the boundary at $H = 0$, or $r = R = \frac{e^2}{2m}$. Since r is the Kerr oblate

coordinate, the bag forms an oblate disk of the radius $r_c \approx a = \frac{1}{2m}$ with thickness $r_e = \frac{e^2}{2m}$, so that $r_e/r_c = e^2 \approx 137^{-1}$.

3. The KN solution may be represented in the Kerr-Schild (KS) form via the both Kerr congruences k_μ^+ or k_μ^- , but not via the both ones simultaneously, [18, 19]. Vector potential A_μ of the KN solution is also to be aligned with the Kerr congruence, and by the use of k_μ^+ or k_μ^- congruence, it turns out to be either retarded, A_{ret} , or advanced, A_{adv} . For the *physical sheet* of the KN solution we chose the outgoing Kerr congruence k_μ^+ , corresponding to the retarded EM field A_{ret} . The fields A_{ret} and A_{adv} cannot reside on the same physical sheet, because each of them should be aligned with the corresponding Kerr congruence. Considering the retarded sheet as a basic physical sheet, we fix the congruence k_μ^+ and the corresponding metric $g_{\mu\nu}^+$, which are not allowed for the advanced field A_{adv} . The field A_{adv} is to be compatible with another congruence k_μ^- , positioned on the separate sheet which different metric $g_{\mu\nu}^-$. It should be emphasized, that this problem disappears inside the bag, where $H = 0$, and the space is flat, $g^\pm = \eta_{\mu\nu}$, and the difference between two metrics disappears. Therefore, the regulated KN spacetime takes again the twosheeted structure outside the bag, as it is illustrated on Fig.2.

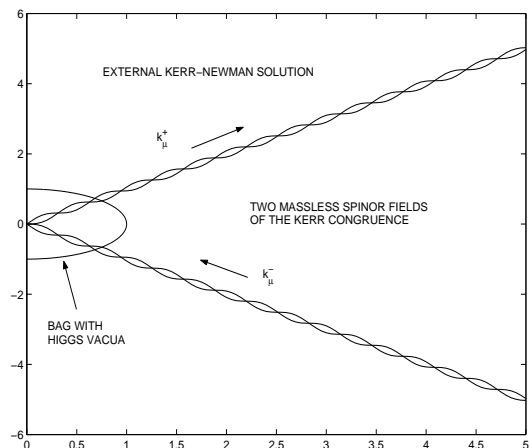

FIG. 2: Two sheets of external KN solution are matched with flat space inside the bag. The massless spinor fields ϕ_α and $\bar{\chi}^{\dot{\alpha}}$ live on different KN sheets, aligned with k_μ^+ and k_μ^- null directions. Inside the bag they join into the Dirac bispinor, getting mass from the Yukawa coupling.

Nevertheless, we obtain that removing the twosheetedness related with the source of KN solution, we meet it again from another side related with advanced potentials outside the regulated bag-like source of KN solution. [36] We discuss here this new effect in details, because it turns out to be related with solutions of the Dirac equation on the KS background.

The Kerr congruences are determined by *the Kerr theorem*, [15, 20–22], which presents for the KN solution two different congruences k_μ^\pm , [14, 15]. The considered

in sec.1 twosheeted structure of the source was related with one of the congruences, k_μ^+ . The second sheet of metric was created by *analytic extension of this congruence* to negative sheet of the KN solution corresponding to $r < 0$. The considered now twosheeted structure has another origin. The two congruences k_μ^\pm are now related with *two different solutions of the Kerr theorem*.

The Kerr theorem determines all the geodesic and *shear free* congruences as analytical solutions of the equation

$$F(T^A) = 0, \quad (6)$$

where F is an arbitrary holomorphic function of the projective twistor variables

$$T^A = \{Y, \zeta - Yv, u + Y\bar{\zeta}\}, \quad A = 1, 2, 3, \quad (7)$$

where $\zeta = (x + iy)/\sqrt{2}$, $\bar{\zeta} = (x - iy)/\sqrt{2}$, $u = (z + t)/\sqrt{2}$, $v = (z - t)/\sqrt{2}$ are null Cartesian coordinates of the auxiliary Minkowski space.

We notice, that the first twistor coordinate Y is also a projective spinor coordinate

$$Y = \phi_1/\phi_0, \quad (8)$$

and it is equivalent to two-component Weyl spinor ϕ_α , which defines the null direction[37] $k_\mu = \bar{\phi}_{\dot{\alpha}}\sigma_\mu^{\dot{\alpha}\alpha}\phi_\alpha$.

It is known, [14, 15, 20], that function F for the Kerr and KN solutions may be represented in the quadratic in Y form,

$$F(Y, x^\mu) = A(x^\mu)Y^2 + B(x^\mu)Y + C(x^\mu). \quad (9)$$

In this case (6) can explicitly be solved, leading to two solutions

$$Y^\pm(x^\mu) = (-B \mp \tilde{r})/2A, \quad (10)$$

where $\tilde{r} = (B^2 - 4AC)^{1/2}$. It has been shown in [15], that these solutions are antipodally conjugate,

$$Y^+ = -1/\bar{Y}^-. \quad (11)$$

Therefore, the solutions (10) determine two Weyl spinor fields ϕ_α and $\bar{\chi}_{\dot{\alpha}}$, which in agreement with (11) are related with two antipodal congruences

$$Y^+ = \phi_1/\phi_0, \quad (12)$$

$$Y^- = \bar{\chi}_1/\bar{\chi}_0. \quad (13)$$

In the Debney-Kerr-Schild (DKS) formalism [20] function Y is also a *projective angular coordinate* $Y^+ = e^{i\phi} \tan \frac{\theta}{2}$. It gives to spinor fields ϕ_α and $\bar{\chi}_{\dot{\alpha}}$ an explicit dependence on the Kerr angular coordinates ϕ and θ .

For the congruence Y^+ this dependence takes the form

$$\phi_\alpha = \begin{pmatrix} e^{i\phi/2} \sin \frac{\theta}{2} \\ e^{-i\phi/2} \cos \frac{\theta}{2} \end{pmatrix}. \quad (14)$$

In agreement with (11) we have $\bar{Y}^- = -e^{-i\phi} \cot \frac{\theta}{2}$, and from the Lorentz invariant normalization $\phi_\alpha \chi^\alpha = 1$ we obtain $\chi_\alpha = \begin{pmatrix} -e^{i\phi/2} \cos \frac{\theta}{2} \\ e^{-i\phi/2} \sin \frac{\theta}{2} \end{pmatrix}$ which yields

$$\bar{\chi}^{\dot{\alpha}} = \epsilon^{\dot{\alpha}\beta} \bar{\chi}_{\dot{\beta}} = \begin{pmatrix} e^{i\phi/2} \sin \frac{\theta}{2} \\ e^{-i\phi/2} \cos \frac{\theta}{2} \end{pmatrix}. \quad (15)$$

These massless spinor fields can be connected to the left-handed and right-handed congruence, and only one of them, say "left", $k_\mu^{(+)}(x)$ is "retarded" and corresponds to the external KN solution. In DKS formalism, the vector field $k_\mu^{(\pm)}(x)$ is determined by the differential form

$$k_\mu dx^\mu = P^{-1}(du + \bar{Y}d\zeta + Yd\bar{\zeta} - Y\bar{Y}dv), \quad (16)$$

where $P = (1 + Y\bar{Y})/\sqrt{2}$ may be considered as a normalizing factor for the time-like component, $k_0^{(\pm)}(x) = 1$. Antipodal map (11) transforms the normalized field $k_\mu^{(+)}(x) = (1, \mathbf{k})$ in the field $k_\mu^{(-)}(x) = (1, -\mathbf{k})$, which retains the time-like direction and reflects the space orientation. Therefore, the spinor fields created by the Kerr theorem ϕ_α and $\bar{\chi}^{\dot{\alpha}}$ correspond to the left out-field and right-in fields, i.e. to the retarded and advanced fields correspondingly.

4. The KN solution belongs to the class of algebraically special Kerr-Schild (KS) solutions, for which all the tensor quantities are to be aligned with null directions of the Kerr congruence k_μ . It means that the consistent solutions of the Dirac equation on the KS background should be aligned with the Kerr congruence. It has been showed in [25] that the Dirac field aligned with KS background should satisfy the linearized Dirac equations

$$\sigma_{\alpha\dot{\alpha}}^\mu i\partial_\mu \bar{\chi}^{\dot{\alpha}} = m\phi_\alpha, \quad \bar{\sigma}^{\mu\dot{\alpha}\alpha} i\partial_\mu \phi_\alpha = m\bar{\chi}^{\dot{\alpha}}, \quad (17)$$

in which gravity drops out. For the Dirac bispinor $\Psi = \begin{pmatrix} \phi_\alpha \\ \bar{\chi}^{\dot{\alpha}} \end{pmatrix}$, the alignment conditions $k^\mu \gamma_\mu \Psi = 0$ turn into equations for eigenfunctions of the helicity operator $(\mathbf{k} \cdot \sigma)$ [26],

$$(\mathbf{k} \cdot \sigma)\phi = \phi, \quad (\mathbf{k} \cdot \sigma)\chi = -\chi, \quad (18)$$

and one sees that the spinor fields ϕ and χ have opposite helicity, forming the "left-handed" ϕ and "right-handed" helicity states, aligned with out-going direction \mathbf{k} and in-going direction $-\mathbf{k}$ correspondingly. In Kerr geometry, these fields should be placed on different sheets corresponding to two antipodal congruences k_μ^\pm obtained from the Kerr theorem. Authors of the paper [25] concluded that these solutions "*are not consistent unless the mass vanishes...*". Indeed, the left-handed part of the Dirac equation is aligned with physical sheet of the KN geometry, while the right-handed parts is aligned with the second sheet obtained under parity inversion of the Kerr null congruence. For the zero mass, the left- and right-hand parts of the Dirac equations decouple, leading to solutions with opposite helicity which are consistent with

different sheets of the KN geometry. In the same time, the both null congruences k_μ^\pm coexist without conflict on the flat space-time, where the massive Dirac equation is consistent with the both Kerr congruences.

In particular, in flat space-time there exist the massive plane wave solutions [26] (v.1, sec. 16 and sec. 23), identified as the *spherical helicity states*

$$\Psi_p = \frac{1}{\sqrt{2\epsilon}} u_p \exp^{-ipx}, \quad (19)$$

where $\epsilon = +\sqrt{p^2 + m^2}$, p is 4-momentum and u_p is the normalized bispinor formed from (14) and (15).

Therefore, the massive Dirac solutions aligned with the both Kerr null directions exist only inside the bag, where the space-time is flat. Outside the bag, the KN gravitational field breaks parity of the left- and right-handed spinors, and the Dirac bispinor splits into the massless left- and right- Weyl spinors which should be placed on the different sheets of the KN solution, as it is illustrated in Fig.2.

5. We arrive at the Dirac equation with a variable mass term which changes for different regions of the space-time. We notice that it is a proper feature of the MIT- and SLAC- bag models related with principal idea of the quark confinement [27, 28]. The quark wave function, solution of the Dirac equation with a variable mass term, is deformed tending to avoid the regions with a large bare mass, and get an energetically favorable position, concentrating inside or on the boundary of the bag.

The bag conception should be applied for the Dirac wave function on the KN background. Taking into account the discussed in sec.1. peculiarities of the gravitating KN bag model, the self-interacting Higgs field should be confined inside the bag. In agreement with (4), the vev of the Higgs field σ should give the mass term $m = g\sigma$ to the Dirac equation through the Yukawa coupling between the left-handed and right-handed spinor fields inside the bag, in full agreement with the results of previous section. The corresponding Hamiltonian is

$$H(x) = \Psi^\dagger \left(\frac{1}{i} \vec{\alpha} \cdot \vec{\nabla} + g\beta\sigma \right) \Psi, \quad (20)$$

and the energetically favorable wave function has to be determined by minimization of the averaged Hamiltonian $\mathcal{H} = \int d^3x H(x)$. Similarly to the approach and the results of the SLAC-bag model, this problem may be solved by variational methods, and the Dirac wave function will apparently be pushed from the region inside the bag, where the bare mass $m = g\eta$ is large, towards a narrow zone at the bag border. As it is claimed in theory of the MIT and SLAC bag models, the very narrow concentration of the Dirac wave function is admissible for scalar potential and does not lead to the Klein paradox.

Concrete form of the wave function depends on the ratio of the parameters σ and η . In the strong coupling limit, $g \rightarrow \infty$, the wave function should concentrate on the shell of the bag. The exact solutions of this kind are known only for two-dimensional case, and the solution of the corresponding variational problem for the KN bag model should apparently be based on numerical computations. One expects that computations will be simplified by the ansatz $\tilde{\Psi} = f(r)\Psi(x)$, where $f(r)$ is a variable factor of the deformation, and the Dirac bispinor Ψ is formed from the Weyl spinors (14) and (15) aligned with the Kerr null congruences.

5. Taking the bag model interpretation, we should also accept the dynamical point of view that the bags may be easily deformed [28, 29]. The known Dirac's model of an "extensible" spherical electron [30] represents apparently a first prototype of the bag model. Under vanishing rotation, $a = 0$, the KN disk-like bag turns into the spherical Dirac "extensible" electron model [38]. In fact, the disk-like bag of the KN rotating source may be considered as a bag obtained by the rotational stretch from the Dirac "extensible" spherical bag. The Kerr parameter of rotation $a = J/m$ stretches the spherical bag to the disk of the Compton radius $a = \hbar/2mc$, which indicates that the KN bag should correspond to the zone of vacuum polarization of a "dressed" electron. Since the degree of oblateness of the KN bag turns out to be very close to $\alpha = 137^{-1}$, the fine structure constant acquires in the KN bag a geometrical interpretation. As it was discussed in [28], deformations of the bag may create stringy structures, and the bags acquire oscillations similar to excitation of a string, [29]. For the KN source, concentration of the wave function at the border of the KN disk results in the appearance of the ring-like string, similar to the Sen fundamental string to low energy heterotic string theory [31]. [39]

We considered soliton source of the KN solution, based on the principle of the minor conflict between KN gravity and quantum theory, and showed that it should represent a gravitating bag model, a generalization of the known MIT and SLAC bag models [27, 28]. Structure the Dirac equation related with KN bag is determined by two-sheeted structure of the KN geometry and strongly correlated with twistorial structure defined by the Kerr theorem. The KN bag realizes a gravitating extension of the Q-ball models, which were suggested in [11–13] for electroweak sector of the standard model, and therefore, the KN bag performs a step beyond the standard model towards its unification with gravity.

Acknowledgments. This work is supported by the RFBR grant 13-01-00602. Author thanks Walter Greiner, Theo M. Nieuwenhuizen, Yuri Rybakov and Bernard Whiting for interest to this work and useful conversations.

[1] G. 't Hooft, The black hole interpretation of string theory, *Nucl. Phys.* **B 335**, 138 (1990); C.F.E. Holzhey and

F. Wilczek, Black Holes as Elementary Particles, *Nucl.*

- Phys. B* **380**, 447 (1992); A. Sen, Extremal black holes and elementary string states, *Mod. Phys. Lett. A* **10** 2081 (1995).
- [2] B. Carter, Global structure of the Kerr family of gravitational fields *Phys. Rev.* **174** 1559 (1968).
- [3] H. Keres, To physical interpretation of the solutions to Einstein equations *Zh. Exp. i Teor. Fiz (ZhETP)* **52** 768 (in Russian) (1967).
- [4] W. Israel, Source of the Kerr metric *Phys. Rev. D* **2** 641 (1970).
- [5] V. Hamity, An interior of the Kerr metric, *Phys. Lett. A* **56**, 77, (1976).
- [6] C. A. López (1984) An extended model of the electron in general relativity *Phys. Rev. D* **30** 313 (1984).
- [7] A. Burinskii, Regularized Kerr-Newman Solution as a Gravitating Soliton, *J. Phys. A: Math. Theor.* **43** (2010) 392001 [arXiv: 1003.2928].
- [8] A. Burinskii, Kerr-Newman electron as spinning soliton, *Int. J. of Mod. Phys. A* **29**(2014) 1450133.
- [9] G. Rosen, Particlelike Solutions to Nonlinear Complex Scalar Field Theories with Positive-Definite Energy Densities. *J. of Math. Phys.* **9** (7) 996 (1968), doi:10.1063/1.1664693 .
- [10] S. Coleman, Q-Balls, *Nuclear Physics B* **262** (2) 263 (1985),
- [11] A. Kusenko, Solitons in the supersymmetric extensions of the standard model, *Phys.Lett. B***405** 108 (1997).
- [12] M.Volkov and E. Wöhnert, Spinning Q-balls, *Phys.Rev. D* **66**, 085003 (2002).
- [13] N.Graham, An Electroweak Oscillon, *Phys.Rev.Lett* **98**, 101801 (2007).
- [14] A. Burinskii and G. Magli, Kerr-Schild approach to the boosted Kerr solutions, *Phys. Rev. D* **61** 044017 (2000).
- [15] A. Burinskii, Stringlike structures in Kerr-Schild geometry: The N=2 string, twistors, and Calabi-Yau twofold, *Theor. Math. Phys.*, **177**(2), 1492 - 1504, (2013).
- [16] P. A. M. Dirac, *Proc. R. Soc. London, Ser. A* **167**, 148 (1938).
- [17] R. Feynman, Space-Time Approach to Quantum Electrodynamics, *Phys. Rev.* **76** 769 (1949).
- [18] Ch.W. Misner, K.S. Thorne and J.A. Wheeler, *Gravitation* v.3, San Francisco: W. Freeman, 1973.
- [19] A. Burinskii, First Award of Gravity Research Foundation, 2009, *Gen. Rel. Gravit.* **41** 2281 (2009), arXiv: 0903.3162[gr-qc]
- [20] G. C. Debney, R. P. Kerr and A. Schild Solutions of the Einstein and Einstein-Maxwell equations *J. Math. Phys.* **10** 1842 (1969).
- [21] D.Kramer, H.Stephani, E. Herlt, M.MacCallum, *Exact Solutions of Einstein's Field Equations*, Cambridge Univ. Press, Cambridge 1980.
- [22] R. Penrose, Twistor Algebra, *J. Math. Phys.* **8** 345 (1967); R. Penrose and W. Rindler, *Spinors and Space-time, Vol. 2: Spinor and twistor methods in space-time geometry*, Cambridge University Press, Cambridge U.K. (1986), pg. 501.
- [23] J. Wess, J. Bagger, *Supersymmetry and Supergravity* (Princeton Univ. Press, Princeton, New Jersey), 1983.
- [24] J. R. Morris, *Phys. Rev. D* **53** 2078 (1996) [arXiv:hep-ph/9511293].
- [25] S. Einstein and R. Finkelstein, Lorentz covariance and the Kerr-Newman geometry, *Phys. Rev. D* **15** 2721 (1977).
- [26] V.B. Berestetsky, E.M. Lifshitz, L.P. Pitaevsky, *Quantum Electrodynamics (Course Of Theoretical Physics, 4)*, Oxford, Uk: Pergamon (1982).
- [27] A. Chodos, R. L. Jaffe, K. Johnson, C. B. Thorn, and V. F. Weisskopf, New extended model of hadrons, *Phys. Rev. D* **9**, 3471 (1974).
- [28] W. A. Bardeen, M. S. Chanowitz, S. D. Drell, M. Weinstein, and T.-M. Yang, Heavy quarks and strong binding: A field theory of hadron structure, *Phys. Rev. D* **11**, 1094 (1974).
- [29] R.C. Giles, Semiclassical dynamics of the "SLAC" bag, *Phys. Rev. D* **13** (1976) 1670,
- [30] P.A.M. Dirac, An Extensible Model of the Electron, *Proc. R. Soc. Lond. A* **268**, 57-67 (1962).
- [31] A. Burinskii, Some properties of the Kerr solution to low-energy string theory, *Phys. Rev. D* **52** (1995) 5826, [arXiv:hep-th/9504139].
- [32] A.Ya. Burinskii, Kerr Spinning Particle, Strings and Superparticle Models. *Phys. Rev.D* **57** (1998) 2392.
- [33] A. Burinskii, Orientifold D-String in the Source of the Kerr Spinning Particle *Phys. Rev. D* **68** (2003) 105004 [arXiv:hep-th/0308096].
- [34] A. Burinskii, Twistorial analyticity and three stringy systems of the Kerr spinning particle, *Phys. Rev. D* **70** (2004) 086006, [arXiv:hep-th/0406063].
- [35] We use signature $(-+++)$.
- [36] Following Dirac and Feynman [16, 17], the retarded potentials A_{ret} can be split into a half-sum and half-difference with advanced ones A_{adv} $A_{ret} = \frac{1}{2}[A_{ret} + A_{adv}] + \frac{1}{2}[A_{ret} - A_{adv}]$, with setting correspondence of the half-difference with radiation reaction and the half-sum with a self-interaction of the source.
- [37] We use the spinor notations of the book [23], where the σ -matrixes has the form $\sigma^\mu = (1, \sigma^i)$, $\bar{\sigma}^\mu = (1, -\sigma^i)$, $i = 1, 2, 3$ and $\sigma^\mu = \sigma_{\alpha\dot{\alpha}}^\mu$, $\bar{\sigma}^\mu = \bar{\sigma}^{\mu\dot{\alpha}\alpha}$.
- [38] The non-rotating spherical KN bag has just the Dirac radius R corresponding to classical radius of electron, $R = r_e = e^2/2m$.
- [39] The real and complex stringy structures of the Kerr geometry were discussed in [32–34].